

SG150 GYRO STABILIZER

Smartgyro SG150 is the gyro stabilizer of choice for boats from 80-95 ft. Ideal for both new builds and refit installations, the stabilizer can be fully serviced on-board the vessel without the need to lift out for maintenance, ensuring significant time and cost savings.



TECHNICAL SPECIFICATIONS

Maximum Rated speed	5.000 RPM	Operating AC power	3.0 - 5.0 kW *
Angular momentum at max. rated speed	37.000 Nms	DC power ("Spool-up" and operating)	250 W (including display)
Anti-rolling torque at max. rated speed	76.000 Nm	Sea water supply	35 (min) - 55 (max) LPM [9 (min) - 15 (max) GPM]
"Spool-up" time to max. rated speed	80 minutes	Operating temperature	0 - 60 °C [32 - 140 °F]
"Spool-up" time to stabilization	45 minutes (65% of rated speed)	Envelope dimensions	1.36 x 1.41 x 1.02 m [53.5 x 55.5 x 40.1 in]
Input voltage (AC)	380V nominal 50/60 Hz, three phase	Weight	1890 kg [3726 lbs]
Input voltage (DC):	24 Vdc	Noise output	72 - 74 dBC @ 1 meter
"Spool-up" AC power	6.5 kW		

*Sea state dependent

NOTE: All data subject to change without notice. Text and illustrations are not binding.

PORT VIEW

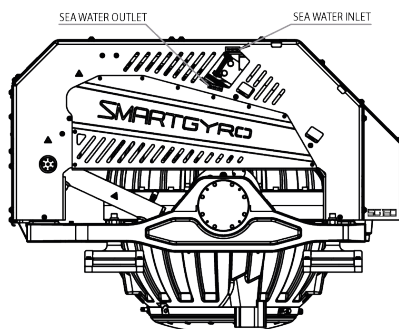

TOP VIEW

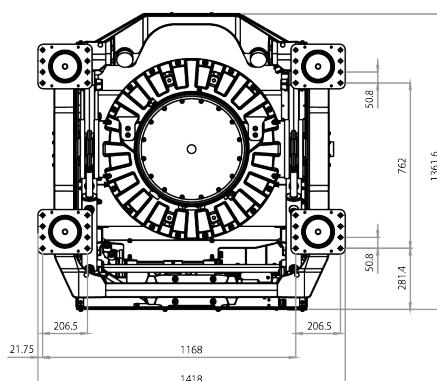

FRONT VIEW

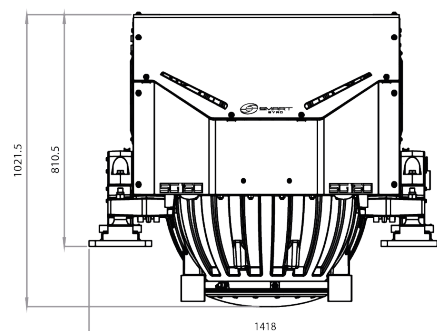

Dimensions in mm